



Synway DTP Series

SHD-30B-CT/PCI/FJ

Digital Trunk Passive Board

Hardware Manual

Version 1.0

Synway Information Engineering Co., Ltd

www.synway.net

Contents

Contents	i
Copyright Declaration	ii
Revision History	iii
Chapter 1 Overview	1
1.1 Functions.....	1
1.2 Features	1
1.3 Operation Principle.....	3
Chapter 2 Installation	4
2.1 Hardware Structure	4
2.2 System Requirements	5
2.3 Installation Procedure	5
Appendix A Technical Specifications	10
Appendix B Technical/sales Support.....	11

Copyright Declaration

All rights reserved; no part of this document may be reproduced or transmitted in any form or by any means, electronic or mechanical, without prior written permission from Synway Information Engineering Co., Ltd (hereinafter referred to as 'Synway').

Synway reserves all rights to modify this document without prior notice. Please contact Synway for the latest version of this document before placing an order.

Synway has made every effort to ensure the accuracy of this document but does not guarantee the absence of errors. Moreover, Synway assumes no responsibility in obtaining permission and authorization of any third party patent, copyright or product involved in relation to the use of this document.

Revision History

Version	Date	Comments
Version 1.0	2007-4	Initial publication

Note: Please visit our website <http://www.synway.net> to obtain the latest version of this document.

Chapter 1 Overview

The DTP Series SHD-30B-CT/PCI/FJ is the digital trunk passive board including PCI bus and can be connected parallelly with E1/T1 trunks via high impedance to obtain call information and voice signals from the line.

1.1 Functions

- Detection of calling/called party info
- A single board has 2 input ports for high-impedance parallel connection and can monitor incoming/outgoing signals to/from 1 E1/T1 port
- Supports China SS1, SS7 (TUP, ISUP) and ISDN call state and voice signal analyses
- Supports independent-recording of incoming, outgoing and mixed-recording modes
- Supports Automatic Gain Control (AGC)
- Supports detection of standard or customized DTMF or single-tone signals
- Activity/silence detection
- Includes H.100 bus, facilitating smooth connectivity to third-party boards with H.100 bus for the transfer of acquired voice signals to other devices.
- The on-board lightning-proof circuit reaches the telecom standard and eliminates the damage caused by the lightning.
- Each board has a unique hardware serial number written in the firmware to distinguish itself from other boards and prevent piracy. The number is available via an easy function call with applications.
- The on-board authorization code identification circuit is designed for software safety. Users can apply to our company for the authorization code.
- Compatible with other series of boards from Synway

1.2 Features

- **PCI 2.2 Bus Support**

Includes PCI 2.2 bus with PCI slot voltage of 3.3V/5V and burst data transmission rate up to 132 MB/s; PNP (plug and play) feature eliminates the need for jumper leads.

- **Full Range of Signaling Systems Support**

Uses the uploadable signaling analysis and processing module, enabling the E1/T1 trunk monitoring under various signaling systems through software configuration without the change of hardware.

- **Various CODECs Support**

Offers a large selection of voice CODECS, including hardware-based A-law (G.711), μ -law, IMA-ADPCM, GSM and G.729A, software-based 16-bit linear PCM, MP3 and VOX.

- **Supports WAV File**

The recorded voice files can be edited and played by audio tools such as Cooledit.

- **High Impedance Connection**

Simply achieved by parallel connection. Very high input impedance rules out interruption on system operation.

- **Automatic Signal-adaptation**

High signal-adaptation capability allows flexible choice of input point on transmission line.

- **Synway's Unified SynCTI Driver Development Platform**

Synway owns the intellectual property rights for the unified high-intelligence SynCTI driver development platform. Each system supports up to 2048 channels. The complex call procedures can be analyzed and controlled through simple function calls on the driver platform, without having to understand details.

1.3 Operation Principle

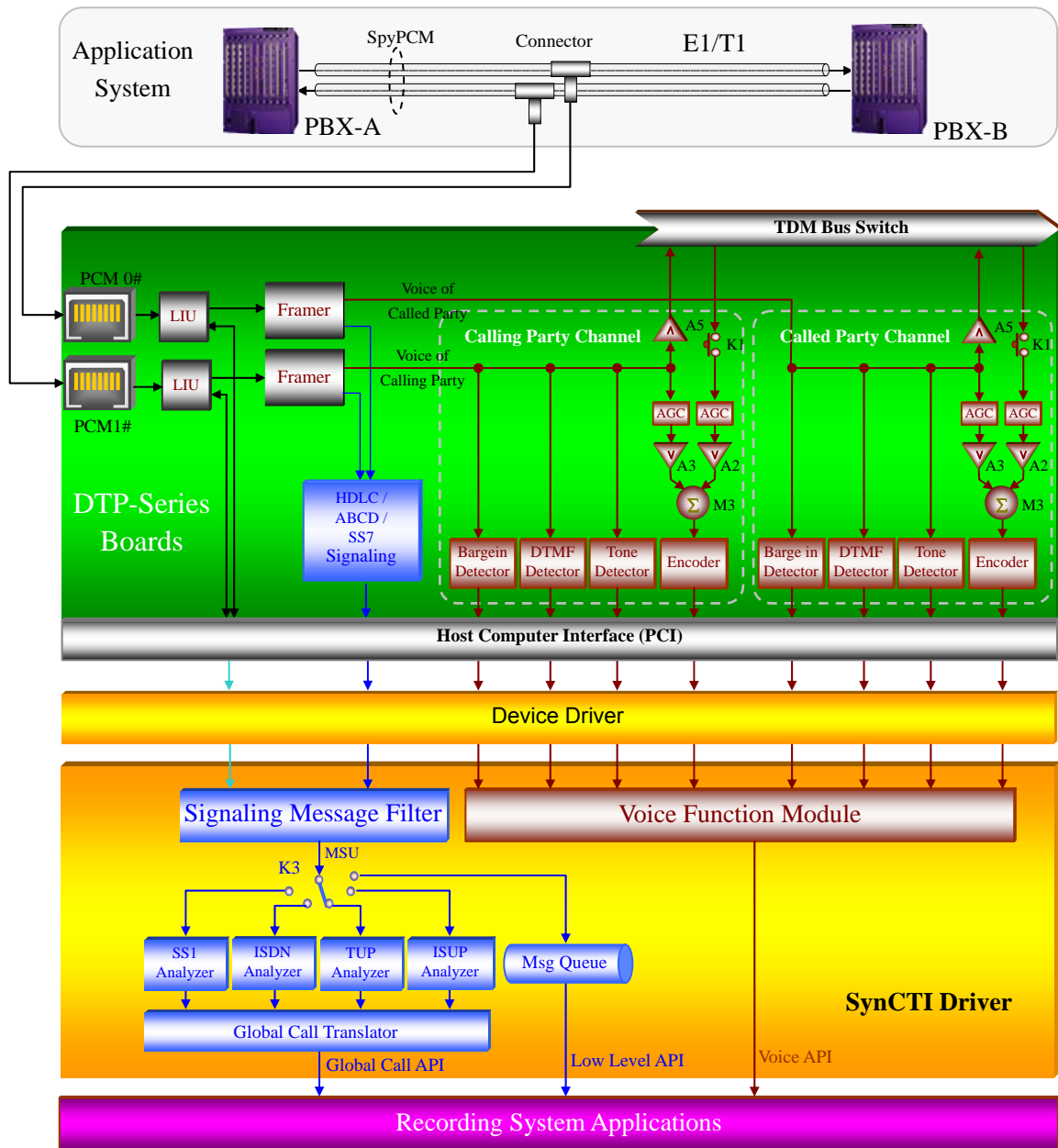

Figure 1-1 Operation Principle

Chapter 2 Installation

2.1 Hardware Structure

- SHD-30B-CT/PCI/FJ board

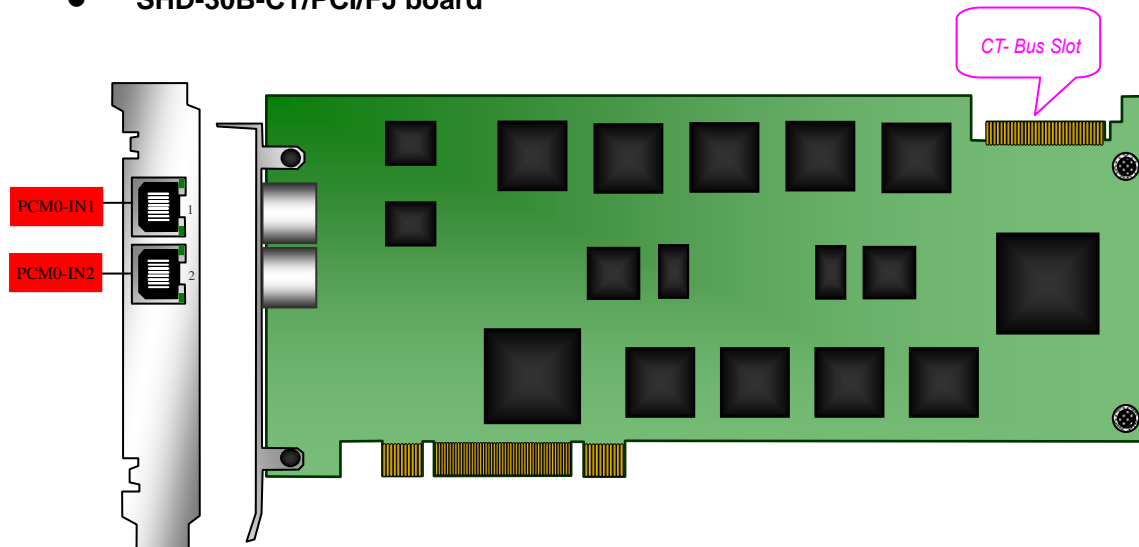

Figure 2-1 Left and Front Side Views

Notes	Description
PCM0-IN1	The first input port for the first E1/T1
PCM0-IN2	The second input port for the first E1/T1

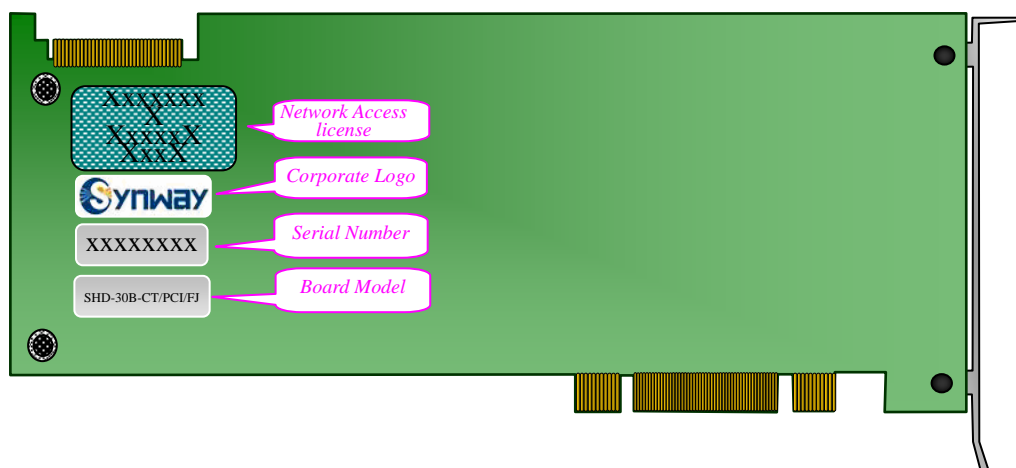

Figure 2-2 Reverse Side View

2.2 System Requirements

Host System Requirements

CPU: 300MHz Intel® Pentium® II or above

Memory: 256M or more

HD: Depends on individual requirements

Supported Operating Systems

Refer to *SynCTI Programmer's Manual.pdf*.

2.3 Installation Procedure

Note: Always turn off the power before installation!

Step 1: Properly fit the board into the PCI slot on the chassis

Step 2: Use the 2-way cable provided with the board to connect the board and external trunks (E1 or T1).

Note: There are two types of this cable. One is used to monitor the twisted-pair cables and called RJ48C Parallel Connection Line (See Figure 2-3); the other is used to monitor the coaxial cables and called RJ48C-to-BNC Adapter (See Figure 2-4).

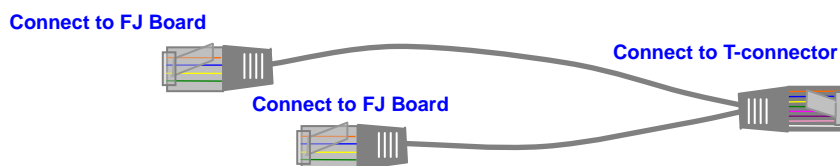

Figure 2-3 RJ48C Parallel Connection Line



Figure 2-4 RJ48C-to-BNC Adapter

Step 3: Connect the board with the devices to be monitored by cables

Connection should be established as shown in Figure 2-5 or Figure 2-6. Users may, according to the actual cable type, choose a T-connector which matches the coaxial or twisted-pair cable interface to connect the board parallelly with the monitored trunk. The cable connected

with the board respectively transfers the incoming and outgoing calls on the monitored trunk to two input ports on the board. Note that in Figure 2-4 only the BNC connector labeled with 'IN' is used for connection.

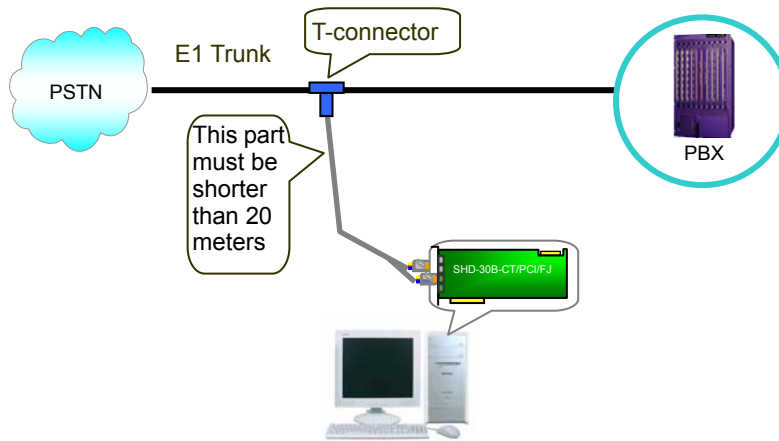

Figure 2-5 Connection Using Twisted-pair Cable

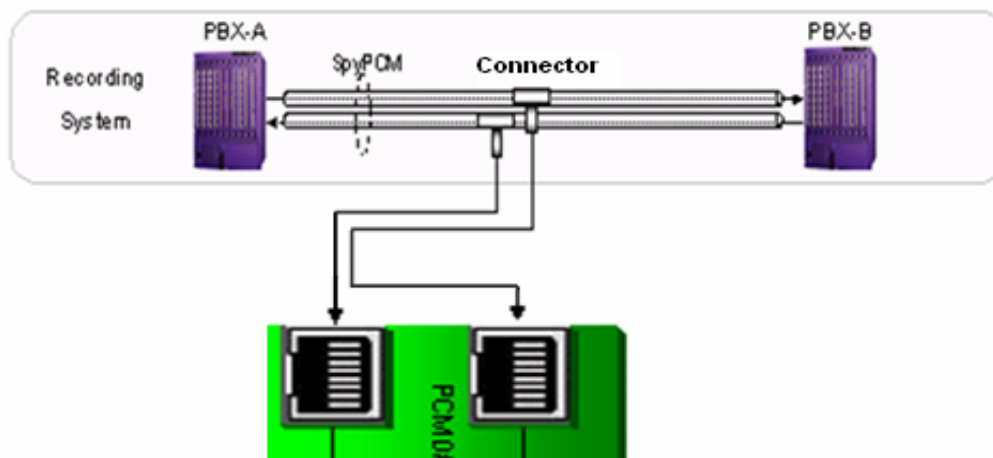

Figure 2-6 Connection Using Coaxial Cable

If you would like to conduct lines (twisted-pair cables) by yourself, pay attention that the cores in the monitored trunk transferring incoming calls must connect with the 1st and 2nd pins of an on-board RJ48C connector and the cores transferring outgoing calls must connect with the 1st and 2nd pins of another RJ48C on the board. Refer to Figure 2-7.

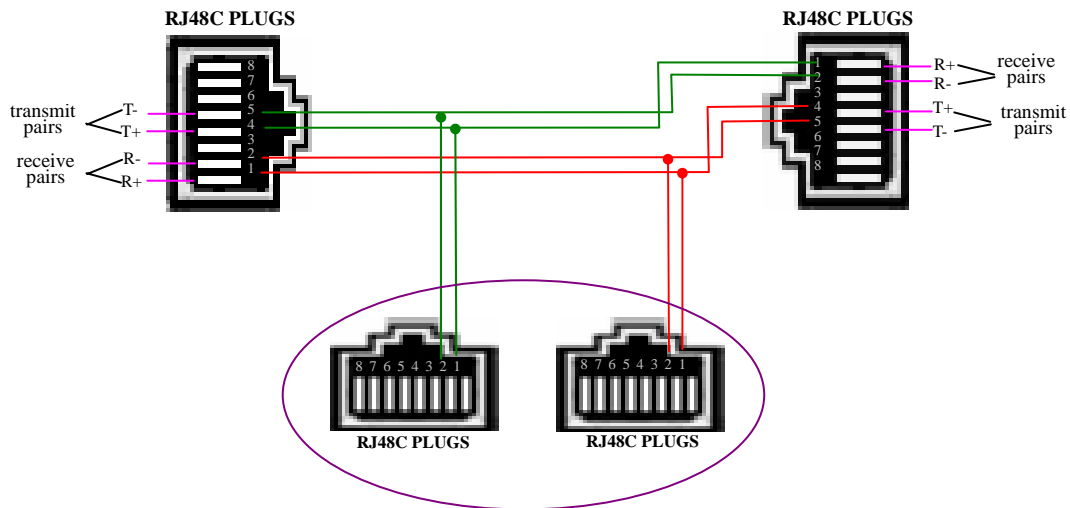

Figure 2-7 Deployment of Monitored Lines

Notes:

- ① Each pair of the RJ48C input ports on the SHD-30B-CT/PCI/FJ board can only monitor incoming and outgoing calls on a same E1 trunk. Which ports monitor the incoming calls and which monitor the outgoing depend on your own configuration.
- ② The T-connector can be freely positioned on the monitored trunks. However, the cable between the T-connector and our board must be limited to 20 meters (the shorter the better) for good communication on the monitored trunk. If this requirement is hard to meet in practice, you may manage to change the path of the monitored trunk and let it pass by our board. If signals through the T-connector have to travel far (over 20 meters), we suggest the use of high-impedance adaptors from Synway.

Step 4: Connect H.100 bus interfaces on all boards by bus cable.

Skip this step if there is no need for bus exchange between multiple boards.

Notes:

- ① See Figure 2-8 for correct insertion. Do not twist or insert in the opposite direction.

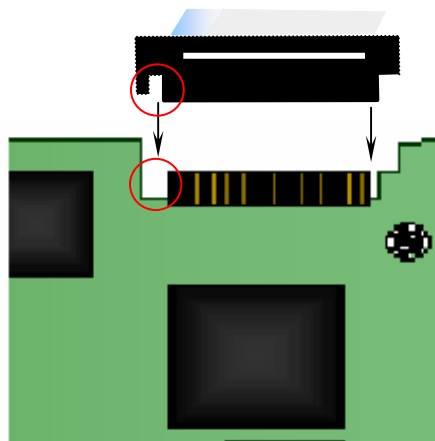

Figure 2-8 Connection of H.100 Bus

- ② There are two clock settings for our boards: When between-board bus exchange is not required, each board sets its own clock and does not have to be connected to the bus cable; otherwise, each board must be connected to the bus cable to follow the clock of the cable.
- ③ The bus cable houses stiff conducting material. Therefore, when it has been shaped, do not bend it repeatedly or violently lest it is broken.

Step 5: Connect to a device allowed to be monitored.

Skip this step if there is no need to 'monitor in real time'.

Notes:

- ① Although the digital trunk passive board does not possess an analog tone signal output interface for monitoring, these purposes can be achieved through linking the board to a pre-installed analog board with playback capabilities over H.100 bus cable.
- ② Also common sound cards can be used for real-time monitoring.

Step 6: Boot your computer and install the driver

Regarding driver installation, refer to the driver installation manual *SynCti_InstManual.pdf*.

Step 7: Configure the operating parameters for the board

Refer to our *SynCTI Programmer's Manual* for details.

Key Tips:

- As the system is expected to run for long hours unmanned, 'energy-saving' mode should be turned off for both the CPU and the HD in CMOS or WINDOWS operating system. This is to ensure full-speed operation of the computer, or it may lead to a drop in performance or unexpected errors after running for some time.
- It is important to ground the chassis with our boards for safety reasons, according to

standard industry requirements. A simple way is earthing with the third pin on the plug. No or improper grounding may cause instability in operation as well as decrease in lightning resistance.

Appendix A Technical Specifications

Dimensions

310×115mm² (excluding L-bracket)

Weight

≈ 250g

Environment

Operation Temperature: 0°C-55°C

Storage Temperature: -20°C-85°C

Humidity: 8%-90% non-condensing

Storage Humidity: 8%-90% non-condensing

Input /output Interface

E1 physical ports: compliant with G703, including
75Ω unbalanced interface and
120Ω balanced interface

T1 physical ports: DSX-1 and CSU line build-outs
available for different extents
of signal losses, including
100Ω and 110Ω balanced
interfaces

Audio Specifications

CODEC: CCITT A/μ-Law 64kbps

IMA ADPCM 32kbps

G.729A 8kbps

GSM 13.6kbps

Frequency Response: 300-3400Hz (±3dB)

Automatic Gain Control (AGC): -20dB-0dB

Signaling

SS1: compliant with international GF002-9002

(DL and MFC)

SS7: compliant with Q771-Q795

DSS1: compliant with Q.933

Maximum System Capacity

Up to 4 boards concurrently per system;
each board can monitor 1 E1/T1 trunk.

H.100 Bus Capacity

4096 channels

Power Requirements

+5V DC: 600mA

Maximum Power Consumption: ≤8W

Input Impedance

≥2400Ω

Audio Encoding/Decoding

16Bit PCM 128kbps

8Bit PCM 64kbps

A-Law 64kbps

μ-Law 64kbps

VOX 32kbps

ADPCM 32kbps

GSM 13.6kbps

MP3 8kbps

G.729A 8kbps

Sampling Rate

8kHz

Safety

Lightning Resistance: Level 4

Appendix B Technical/sales Support

Thank you for choosing Synway. Please contact us should you have any inquiry regarding our products. We shall do our best to help you.

Headquarters

Synway Information Engineering Co., Ltd

<http://www.synway.net/>

9F, Synway D&R Center, No.3756, Nanhuan Road, Binjiang District,
Hangzhou, P.R.China, 310053

Tel: +86-571-88860561

Fax: +86-571-88850923

Technical Support

Tel: +86-571-88864579

Mobile: +86-13735549651

Email: techsupport@sanhuid.com

Email: techsupport@synway.net

MSN: scycindy_sh@hotmail.com

Sales Department

Tel: +86-571-88860561

Tel: +86-571-88864579

Fax: +86-571-88850923

Email: sales@synway.net