



Synway ATP Series

**ATP-24A/PCI(2.0)
ATP-24A/PCI+(2.0)
ATP-24A/PCIe(3.0)
ATP-24A/PCIe+(3.0)**

Analog Tap Passive Board

Hardware Manual

Version 4.1

Synway Information Engineering Co., Ltd

www.synway.net

Contents

Contents	i
Copyright Declaration	ii
Revision History	iii
Chapter 1 Overview	1
1.1 Functions	1
1.2 Features	1
1.3 Operation Principle	3
1.4 Functional Modules.....	3
Chapter 2 Installation	4
2.1 Hardware Structure.....	4
2.2 System Requirements.....	7
2.3 Installation Procedure	8
Appendix A Technical Specifications	11
Appendix B Technical/sales Support	12

Copyright Declaration

All rights reserved; no part of this document may be reproduced or transmitted in any form or by any means, electronic or mechanical, without prior written permission from Synway Information Engineering Co., Ltd (hereinafter referred to as 'Synway').

Synway reserves all rights to modify this document without prior notice. Please contact Synway for the latest version of this document before placing an order.

Synway has made every effort to ensure the accuracy of this document but does not guarantee the absence of errors. Moreover, Synway assumes no responsibility in obtaining permission and authorization of any third party patent, copyright or product involved in relation to the use of this document.

Revision History

Version	Date	Comments
Version 1.0	2008-9	Initial publication
Version 1.1	2009-5	New revision
Version 2.0	2010-5	Add description on new board models ATP-24A/PCI(2.0), ATP-24A/PCI+(2.0), ATP-24A/PCle(2.0), ATP-24A/PCle+(2.0).
Version 3.0	2012-4	Add description on new board models ATP-24A/PCle(3.0), ATP-24A/PCle+(3.0).
Version 4.0	2013-11	Add description on new board models ATP-24A/PCle(4.0), ATP-24A/PCle+(4.0).
Version 4.1	2015-7	Delete description on board models ATP-24A/PCI, ATP-24A/PCI+, ATP-24A/PCle, ATP-24A/PCle+, ATP-24A/PCle(2.0), ATP-24A/PCle+(2.0), ATP-24A/PCle(4.0), ATP-24A/PCle+(4.0).

Note: Please visit our website <http://www.synway.net> to obtain the latest version of this document.

Chapter 1 Overview

The Synway ATP Series ATP-24A/PCI(2.0), ATP-24A/PCI+(2.0), ATP-24A/PCle(3.0), ATP-24A/PCle+(3.0) are 24-channel analog tap passive boards with PCI or PCle bus, used especially for recording of analog subscriber lines.

1.1 Functions

- High-impedance passive monitoring through parallel connection
- A variety of ways to start/stop recording
- Support of simultaneous recording on 24 channels
- Caller ID detection, FSK/DTMF support
- DTMF digits detection
- Simultaneous detection of DTMF and FSK
- Programmable tone analyzer detects all kinds of tones
- Activity/silence detection
- Automatic Gain Control (AGC) support in recording/playback operation
- Call progress monitoring
- Automatic detection of line voltage
- Automatically checks board to see if recording modules are correctly inserted
- ATP-24A/PCI+(2.0) and ATP-24A/PCle+(3.0) boards support hardware-based MS-GSM, G.729A and MP3 formats for encoding
- ATP-24A/PCle(3.0) and ATP-24A/PCle+(3.0) boards support the beep tone feature

1.2 Features

- **PCI 2.2 Bus Support**

(ATP-24A/PCI(2.0), ATP-24A/PCI+(2.0))

These four boards include PCI 2.2 bus with burst data transmission rate up to 133 MB/s; the PNP (plug and play) feature they have eliminates the need for jumper leads; also they support 3.3V/5V slot voltage and PCI-X.

- **PCle Bus Support**

(ATP-24A/PCle(3.0), ATP-24A/PCle+(3.0))

Developed with the design of PCle X1, these six boards support PCle X1, X2, X4, X8 and X16 slots.

- **DMA Transfer Support**

The DMA transfer of recording data does not cost any of the host CPU resources, which helps extend the capacity of recording lines on a single board to an extreme.

- **Modularized Design**

This board is designed with modularized structure and can be configured in flexible ways. Each board is equipped with 8 recording units and can be fitted with up to 2 recording modules. Each module supports the recording of 8 analog phone lines. Now it is widely used in various systems.

- **Available RJ21 Connector**

Each board has a 50-pin RJ21 connector which is often used for PBXs; with the help of a 24-port RJ21-to-RJ11 adapter that is supplied with the board, users can use the RJ11 jack for direct connection.

- **Fits Modules via Inter-plane Connectors**

The use of high-precision inter-plane connectors highlights the compact characteristic and highly-reliable advantages of Synway's all-in-one boards.

- **8 to 24 Port Hi-Z Monitoring of Analog Lines**

Flexible positioning of the tapping point is allowed on the communication line between Central Office Terminal (COT) and PBX, COT and telephones, PBX and telephones, as well as any kind of analog audio signals, e.g. radio signals. This function is widely used in small-to-large capacity call recording systems, call centers and so on.

- **Programmable Tone Detector**

Detects single or dual tones at any frequency, offering facility for use with a variety of PBXs and key telephone systems.

- **High-impedance Recording**

The recording impedance is up to 10kΩ AC/2MΩ DC (8kΩ AC/2MΩ DC for ATP-24A 3.0 series boards), ruling out the interruption on transmission of monitored signals.

- **Various CODECs Support**

Offers a large selection of voice CODECs, including hardware-based A-Law (G.711), μ-law, IMA-ADPCM, software-based 16-bit linear PCM, MP3 and VOX. The ATP-24A/PCI+(2.0) and ATP-24A/PCIe+(3.0) boards also support the hardware-based MS-GSM, G.729A and MP3 formats for encoding.

- **Beep Tone Feature**

ATP-24A/PCIe(3.0) and ATP-24A/PCIe+(3.0) boards support the beep tone feature. The gains of the tones are adjustable. By default, the tone sent out from local has the gain of -4dBm. If its frequency is 1 KHz, the gain turns to -24dBm when it arrives at the line.

- **Supports WAV File**

The recorded voice files can be edited and played by audio tools such as Cooledit.

- **Audio Output Interface**

Equipped with an analog tone amplifier circuit and an output interface, the first channel (0#) on the board can directly connect to the headset or sound box, allowing monitoring of a specified channel in real time and voice playback only via a simple function call.

- **Unique Hardware Serial Number**

Each board has a unique hardware serial number written in the firmware to distinguish itself from other boards and prevent piracy. The number is available via an easy function call with applications.

- **Authorization Code Identification Circuit**

The on-board authorization code identification circuit is designed for software safety. Users can apply to our company for an exclusive one.

- **Synway’s Unified SynCTI Driver Development Platform**

Synway owns the intellectual property rights for the unified high-intelligence SynCTI driver development platform. Each system supports up to 2048 channels. Functions such as the detection and analysis of rings, tones and Caller IDs, the generation of beep tones, are all available via simple function calls on the driver platform, without having to understand complex call procedures.

1.3 Operation Principle

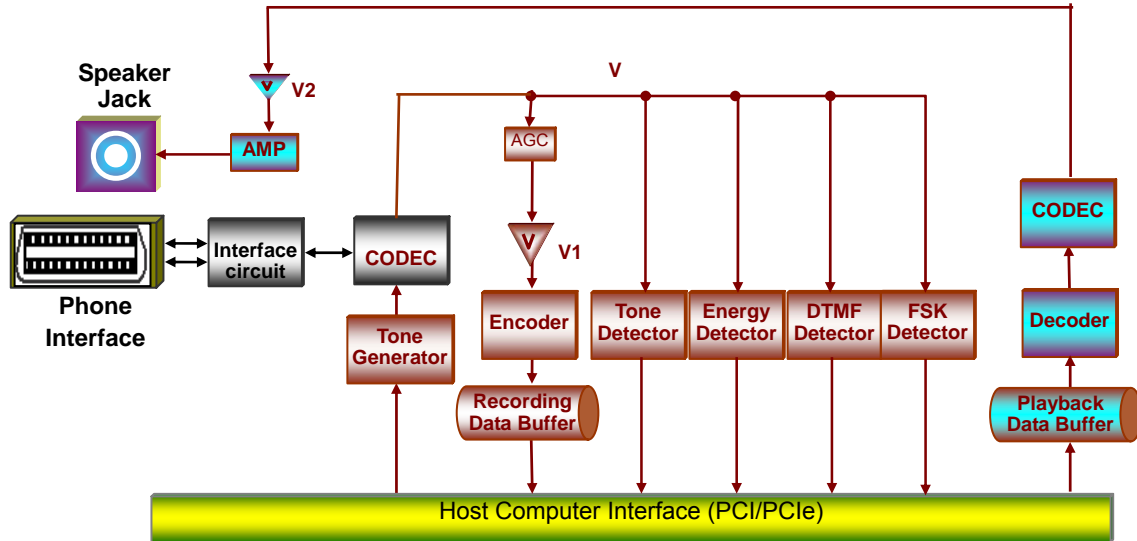

Figure 1-1 Operation Principle

1.4 Functional Modules

- **High-impedance Recording Module**

Equipped with high-impedance input interfaces, this module is used for the recording of local lines, extension lines, dynamic microphones and other audio tones. See Figure 2-6, Figure 2-7, Figure 2-8 and Figure 2-9 below for the hardware structure.

Chapter 2 Installation

2.1 Hardware Structure

- ATP-24A/PCI(2.0), ATP-24A/PCI+(2.0) Boards

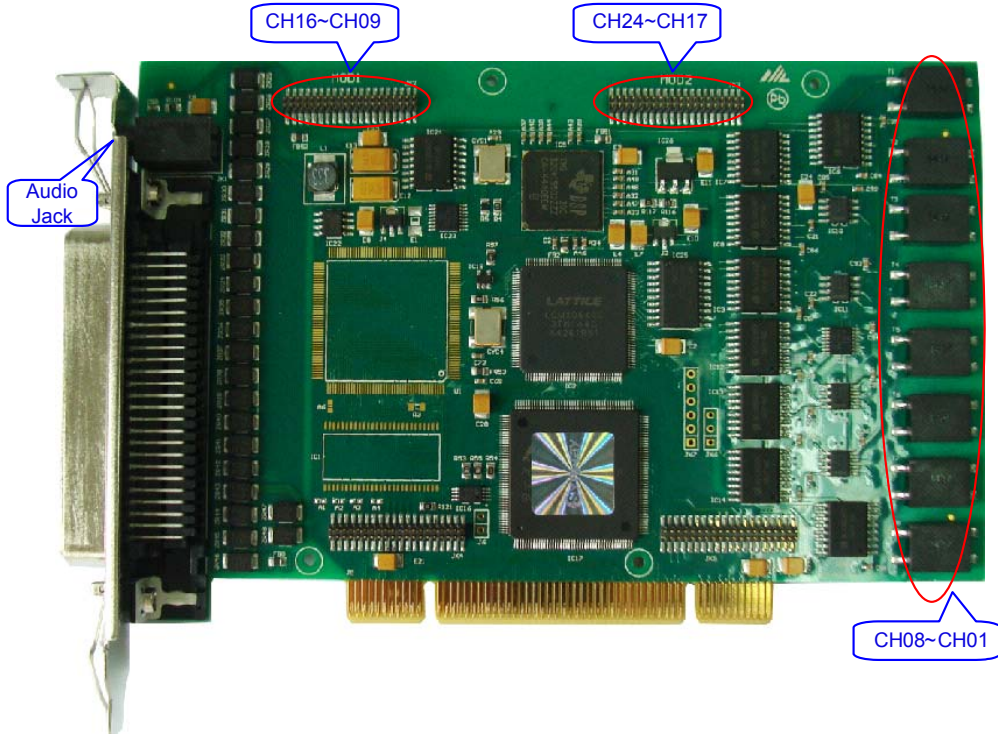

Figure 2-1 ATP-24A/PCI(2.0) (Front View)

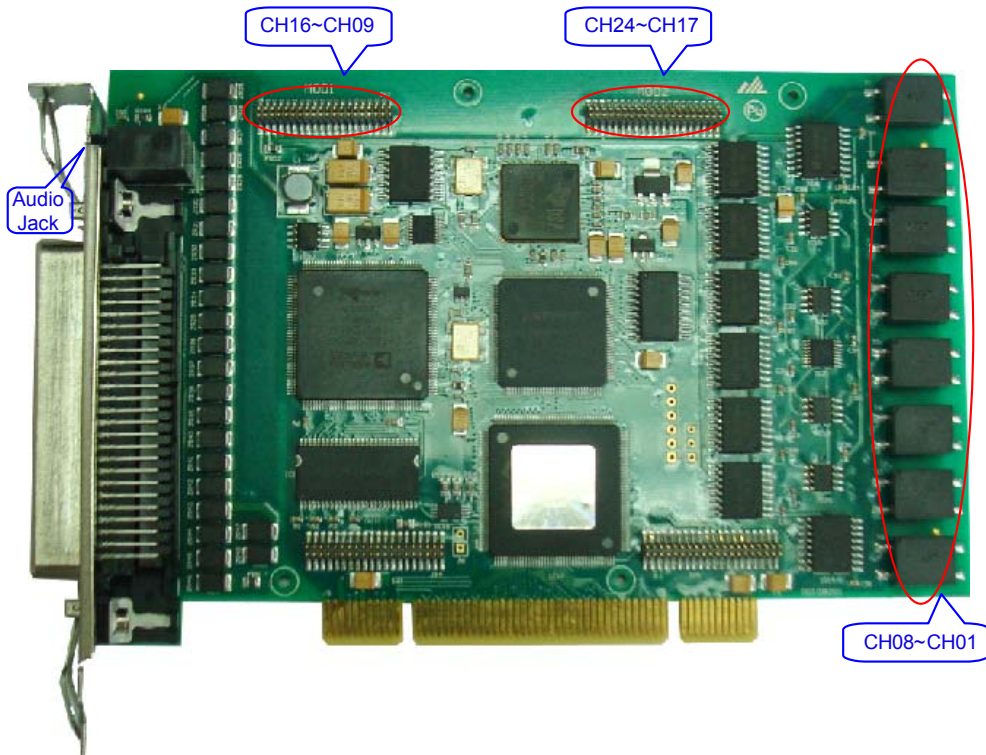

Figure 2-2 ATP-24A/PCI+(2.0) (Front View)

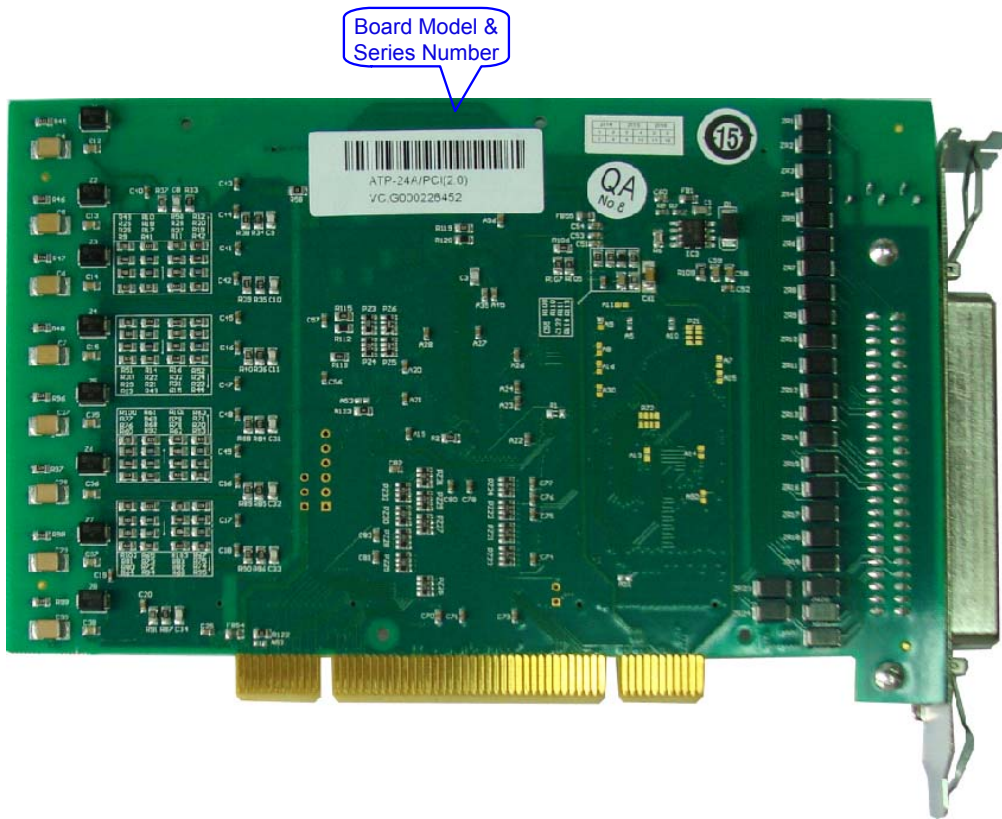

Figure 2-3 ATP-24A/PCI(2.0), ATP-24A/PCI+(2.0) (Rear View)

● **ATP-24A/PCIe+(3.0) Boards**

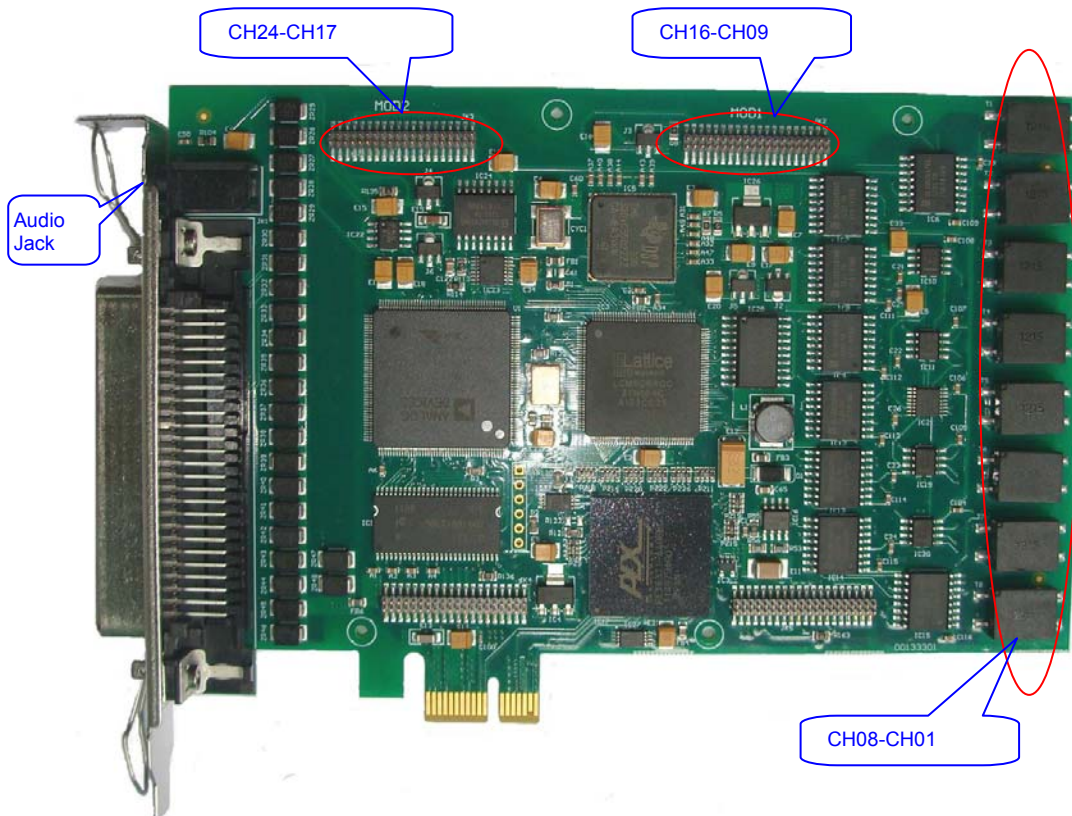

Figure 2-4 ATP-24A/PCIe+(3.0) (Front View)

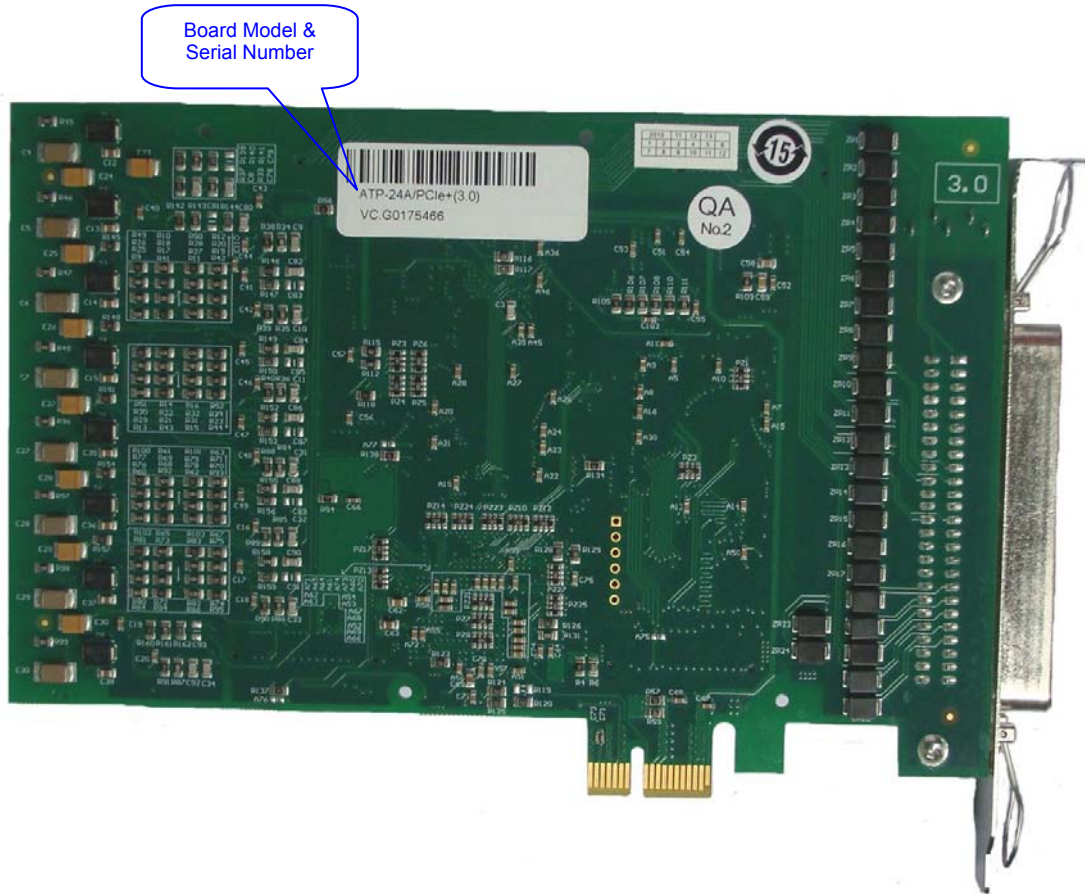

Figure 2-5 ATP-24A/PCIe+(3.0) (Rear View)

- **MOD_24A High-impedance Recording Module**

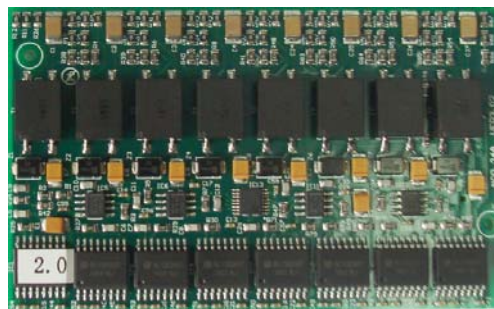

Figure 2-6 MOD_24A (Version 2.00) High-impedance Recording Module (Front View)

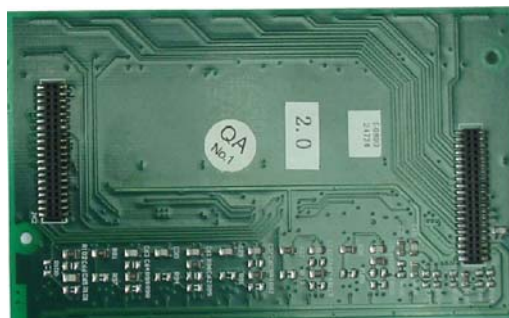

Figure 2-7 MOD_24A (Version 2.00) High-impedance Recording Module (Rear View)

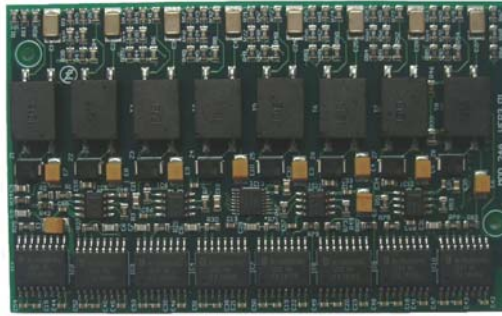

Figure 2-8 MOD_24A (Version 3.00) High-impedance Recording Module (Front View)



Figure 2-9 MOD_24A (Version 3.00) High-impedance Recording Module (Rear View)

● **Interface Description:**

Each board has a 50-pin RJ21 connector. The physical pin layout of the on-board RJ-21 connector is shown in Figure 2-10. Chn-a and Chn-b are a pair of phone lines, and an RJ-21 connector can connect with 24 pairs of phone lines at the same time.

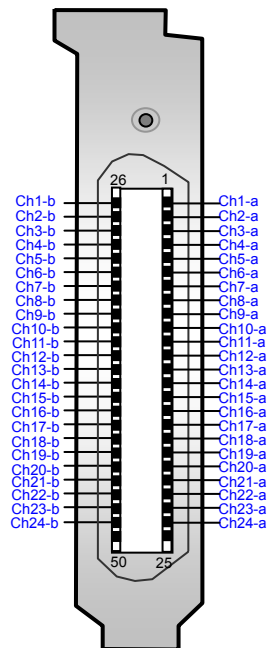

Figure 2-10 RJ21 Pin Layout

2.2 System Requirements

Host System Requirements

CPU: 300MHz Intel® Pentium® II or above

Memory: 256M or more

HD: Depends on individual requirements

Supported Operating Systems

Refer to SynCTI Programmer's Manual.pdf.

2.3 Installation Procedure

Note: Always turn off the power before installation!

Step 1: Properly fit the board with modules into the PCI slot on the chassis.

Step 2: Connect the board to analog phone lines

Connect one end of the phone line to a point on the communication line between the PBX and a telephone, and the other end to the on-board RJ21 connector or to the RJ21-to-RJ11 adapter linked with the board.

Notes on Connection:

- ① For version 3.0 and below, in case of connection to RJ11 jacks, our company provides an RJ21 connecting line and an RJ21-to-RJ11 adapter, and recommends the following connection methods:

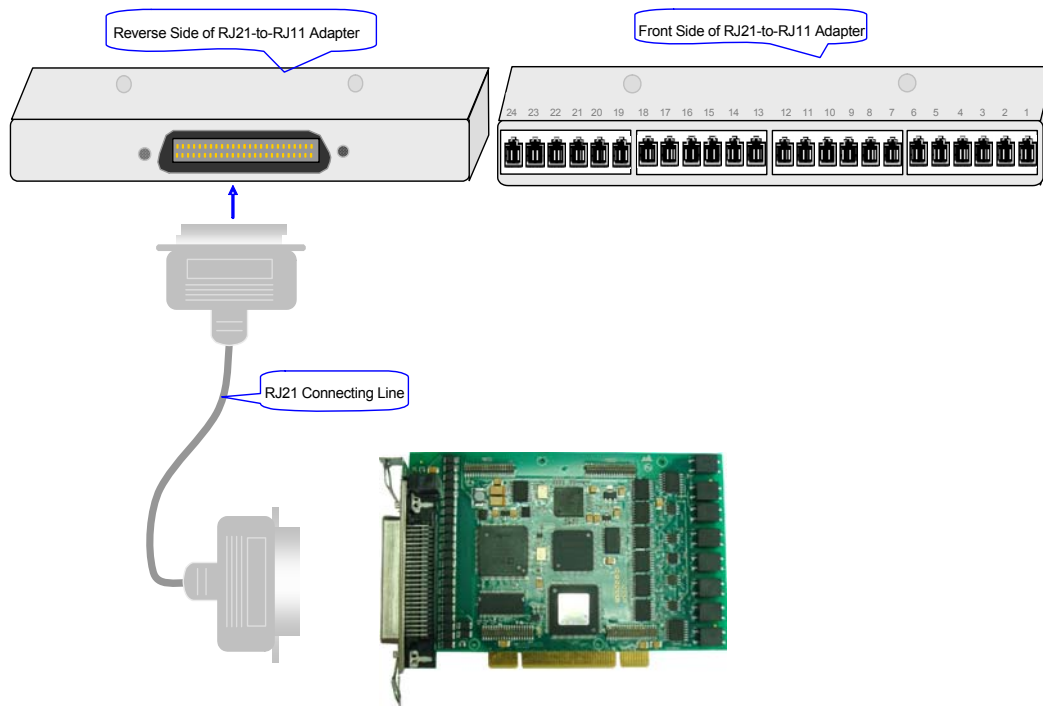

Figure 2-11 ATP-24A Board Connection Model (Version 3.0 and below)

- ② In case of direct connection to the on-board RJ21 connector, we suggest the following connection methods:

Perform a corresponding connection of Chn-a and Chn-b for each pair of phone lines as shown in Figure 2-12 below.

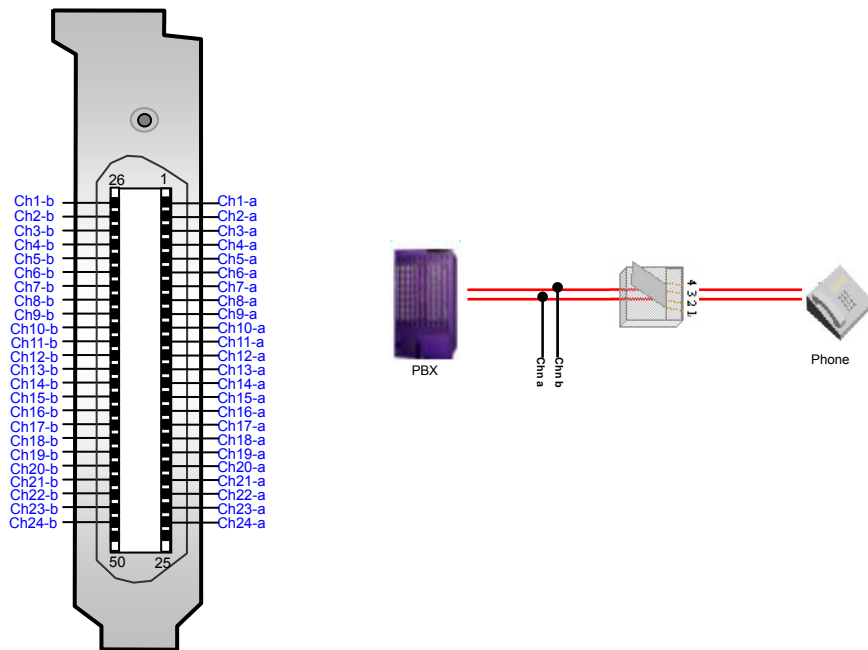

Figure 2-12

Note: The RJ21 connecting line we provide has 3 specifications (3m, 5m and 10m) for you to choose. They are all 25-twisted-pair communication cables using the international standard spectrum, can connect directly to our board. The 25 pairs of pins in RJ21 can be arranged by color in two different ways. See Table 2-1 and Table 2-2 for details. (To be exact, the 1st and the 26th pins are the first pair; the 2nd and the 27th pins constitute the second pair; ...; the 24th and the 49th pins are the 24th pair; the 25th and the 50th pins constitute the 25th pair. Actually, only the first 24 pairs are used by 24-channel boards.)

Pair Number	1	2	3	4	5	6	7	8
Color	White Blue	White Orange	White Green	White Brown	White Grey	Red Blue	Red Orange	Red Green
Pair Number	9	10	11	12	13	14	15	16
Color	Red Brown	Red Grey	Black Blue	Black Orange	Black Green	Black Brown	Black Grey	Yellow Blue
Pair Number	17	18	19	20	21	22	23	24
Color	Yellow Orange	Yellow Green	Yellow Brown	Yellow Grey	Purple Blue	Purple Orange	Purple Green	Purple Brown

Table 2-1

Pair Number	1	2	3	4	5	6	7	8
Color	Black Grey	Black Brown	Black Orange	Black Green	Black Blue	Red Grey	Red Brown	Red Orange
Pair Number	9	10	11	12	13	14	15	16
Color	Red Green	Red Blue	Yellow Grey	Yellow Brown	Yellow Orange	Yellow Green	Yellow Blue	Purple Grey
Pair Number	17	18	19	20	21	22	23	24
Color	Purple	Purple	Purple	Purple	White	White	White	White

	Brown	Orange	Green	Blue	Grey	Brown	Orange	Green
--	-------	--------	-------	------	------	-------	--------	-------

Table 2-2

Step 3: Connect the sound box or other proper sound devices.

Skip this step if there is no need to ‘monitor in real time’ or ‘play’.

Regarding how to choose proper sound devices, refer to ‘Input/output Interface’ and ‘Audio Specifications’ in *Appendix A Technical Specifications*.

Step 4: Boot your computer and install the driver.

Regarding driver installation, refer to the document *SynCti_InstManual.pdf*.

Step 5: Add a statement to the configuration file to enable the high-powered compression for the ATP-24A/PCI+(2.0) and ATP-24A/PCIe+(3.0) boards.

It is not allowed to use GSM and G.729A at a same time for recording. To enable the high-powered compression, add the following content under the section [BoardId=x] in the file *shconfig.ini*.

For GSM recording: `ldr531=bf531_gsm.ldr;`

For G.729A recording: `ldr531=bf531_729.ldr.`

Skip this step if there is no request for high-powered compression.

Key Tips:

- As the system is expected to run for long hours unmanned, ‘energy-saving’ mode should be turned off for both the CPU and the HD in CMOS or WINDOWS operating system. This is to ensure full-speed operation of the computer, or it may lead to a drop in performance or unexpected errors after running for some time.
- A chassis installed with analog tap passive boards must be grounded for safety reasons, according to standard industry requirements. A simple way is earthing with the third pin on the plug. No or improper grounding may cause instability in operation as well as decrease in lightning resistance.

Appendix A Technical Specifications

Dimensions

ATP-24A/PCI(2.0), ATP-24A/PCI+(2.0):

160×111mm² (excluding L-bracket)

ATP-24A/PCle(3.0), ATP-24A/PCle+(3.0):

160×111mm² (excluding L-bracket)

Weight

ATP-24A/PCI(2.0), ATP-24A/PCI+(2.0):

≈215g (including 2 8-channel modules)

ATP-24A/PCle(3.0), ATP-24A/PCle+(3.0):

≈215g (including 2 8-channel modules)

Environment

Operating temperature: 0 °C—55 °C

Storage temperature: -20 °C—85 °C

Humidity: 8%— 90% non-condensing

Storage humidity: 8%— 90% non-condensing

Input/output Interface

Headset jack: One ϕ 3.5 stereo jack

Telephone line jack: A 50-pin RJ21 connector

Audio Specifications

Codec: CCITT A/ μ -Law 64kbps

IMA ADPCM 32kbps

Output power: \geq 50mW

Distortion: \leq 2%

Frequency response: 300-3400Hz(\pm 3dB)

Signal-to-noise ratio: \geq 38dB

Echo suppression: \geq 40dB

Maximum System Capacity

Up to 10 boards concurrently per system; up to

24 channels per board

Power Requirements

ATP-24A/PCI(2.0), ATP-24A/PCI+(2.0):

+3.3V DC: 900mA

+5V DC: 200mA

+12V DC: 100mA

Maximum power consumption: \leq 6W (PC

power supply only)

ATP-24A/PCle(3.0), ATP-24A/PCle+(3.0):

+3.3VDC: 900mA

+12V DC: 300mA

Maximum power consumption: \leq 7.5W (PC

power supply only)

Impedance

Input impedance: \geq 1M Ω /500V DC;

\geq 10k Ω /1000V AC

ATP-24A/PCle(3.0), ATP-24A/PCle+(3.0):

\geq 1M Ω /500V DC;

\geq 8k Ω /1000V AC

Insulation resistance for PC isolation from

telephone line: \geq 2M Ω /500V DC

Telephone line impedance: Compliant with the

national standard impedance for

three-component network

Audio Encoding & Decoding

16Bit PCM 128kbps

8Bit PCM 64kbps

A-Law 64kbps

μ -Law 64kbps

VOX 32kbps

ADPCM 32kbps

GSM 13.6kbps

MP3 8kbps

G.729A 8kbps

Sampling Rate

8kHz

Safety

Lightning resistance: Level 4

Monitoring Distance

The maximum distance between the ATP board

and the access point is 50m.

Appendix B Technical/sales Support

Thank you for choosing Synway. Please contact us should you have any inquiry regarding our products. We shall do our best to help you.

Headquarters

Synway Information Engineering Co., Ltd

<http://www.synway.net/>

9F, Synway D&R Center, No.3756, Nanhuan Road, Binjiang District, Hangzhou, P.R.China, 310053

Tel: +86-571-88860561

Fax: +86-571-88850923

Technical Support

Tel: +86-571-88864579

Mobile: +86-18905817070

Email: techsupport@sanhuid.com

Email: techsupport@synway.net

MSN: synway.support@hotmail.com

Sales Department

Tel: +86-571-88860561

Tel: +86-571-88864579

Fax: +86-571-88850923

Email: sales@synway.net