



Synway ATP Series

**SHT-16B-CT/PCI
SHT-16B-CT/PCI/MP3**

Analog Tap Passive Board

Hardware Manual

Version 2.1

Synway Information Engineering Co., Ltd

www.synway.net

Contents

Contents	i
Copyright Declaration	ii
Revision History	iii
Chapter 1 Overview	1
1.1 Functions	1
1.2 Features	1
1.3 Operation Principle	4
1.4 Functional Modules	4
Chapter 2 Installation	5
2.1 Hardware Structure	5
2.2 System Requirements	7
2.3 Installation Procedure	7
Appendix A Technical Specifications	11
Appendix B Technical/sales Support.....	12

Copyright Declaration

All rights reserved; no part of this document may be reproduced or transmitted in any form or by any means, electronic or mechanical, without prior written permission from Synway Information Engineering Co., Ltd (hereinafter referred to as 'Synway').

Synway reserves all rights to modify this document without prior notice. Please contact Synway for the latest version of this document before placing an order.

Synway has made every effort to ensure the accuracy of this document but does not guarantee the absence of errors. Moreover, Synway assumes no responsibility in obtaining permission and authorization of any third party patent, copyright or product involved in relation to the use of this document.

Revision History

Version	Date	Comments
Version1.0	1997-5	For overseas markets only
Version1.1	1999-2	Rearranged edition: Added description of interfaces and the connection between them
Version2.0	2003-10	Changes: Modified the hardware description, added figures of boards and modules for better understanding
Version2.1	2006-6	Changes: Separated call-recoding products from the CTI series to be a new series

Note: Please visit our website <http://www.synway.net> to obtain the latest version of this document.

Chapter 1 Overview

The ATP Series SHT-16B-CT/PCI is a 16-channel analog tap passive board including PCI bus. By configuring different recording modules in different ways, this board can be used for recording of analog phone lines via high impedance and direct recording of microphones.

1.1 Functions

- High-impedance connection ensures no interruption of data transmission on the monitored line
- A variety of ways to start/stop recording
- Supports simultaneous recording on 16 channels, each with a different format
- Caller ID detection, DTMF and FSK support
- DTMF digits detection
- Programmable tone analyzer detects all kinds of tones
- Activity/silence detection
- AGC support in recording/playback operation
- Call progress monitoring
- Automatic line voltage detection
- Automatically checks board to see if recording modules are correctly inserted

1.2 Features

- **PCI 2.1 Bus Support**

Includes PCI 2.1 bus with burst data transmission rate up to 133 MB/s; PNP (plug and play) feature eliminates the need for jumper leads
- **Module Configurable**

8 on-board dual channel modules can be freely arranged in pairs or groups for various complex combination applications, such as call center and recording functions available on a single board.
- **On-board SIMM Slots**

Fit recording modules to board. Contacts on both sides of the SIMM slots greatly improve connection and ease installation.
- **RJ45 Jack**

A single board has four 8-pin RJ45 jacks, each of which can be converted into four 2-pin RJ11 jacks via a proper 4-way hub, making connection easy and malfunctions rare.

- **2 to 16 Port Hi-Z Monitoring of Analog Lines**

Flexible positioning of the access point on the communication line between Central Office Terminal (COT) and PBX, COT and telephones, PBX and telephones, etc. allows monitoring of any analog tone signal such as tone signals from radio station. This function is widely used in small-to-large capacity call recording systems, call centers and microphone recording systems.

- **Programmable Tone Detector**

Detects single or dual tones at any frequency, offering facility for use with a variety of switches and enterprise phone systems

- **High-impedance Recording**

The recording impedance is up to $10K\Omega$ AC/ $2M\Omega$ DC, ruling out interruption on transmission of monitored signals.

- **Various CODECs Support**

Offers a large selection of voice CODECs, including hardware-based A-law (G.711), μ -law, MP3, IMA-ADPCM, software-based 16-bit linear PCM and VOX.

- **Supports WAV File**

The recorded speech files can be edited and played by audio tools such as Cooledit.

- **Audio Output Interface**

The first channel on the board equipped with an analog tone amplifier circuit and an output interface, can directly connect to the headset or sound box, and monitor a specified channel in real time via a simple function call.

- **TDM Capability**

Includes H.100 bus, facilitating smooth connectivity to third-party boards with H.100 bus for the transfer of acquired voice signals to other devices

- **Unique Hardware Serial Number**

Each board has a unique hardware serial number written in the firmware to distinguish itself from other boards and prevent piracy. The number is available via an easy function call with applications.

- **Authorized Code Identification Circuit**

The on-board authorized code identification circuit is designed for software safety. Users can apply to our company for the authorized code.

- **Synway's Unified SynCTI Driver Development Platform**

Synway owns the intellectual property rights for the unified high-intelligence SynCTI driver development platform. Each system supports up to 2048 channels. Functions such as the detection and analysis of rings, tones and Caller IDs, are available via simple function calls on the driver platform, without having to understand complex call procedures.

1.3 Operation Principle

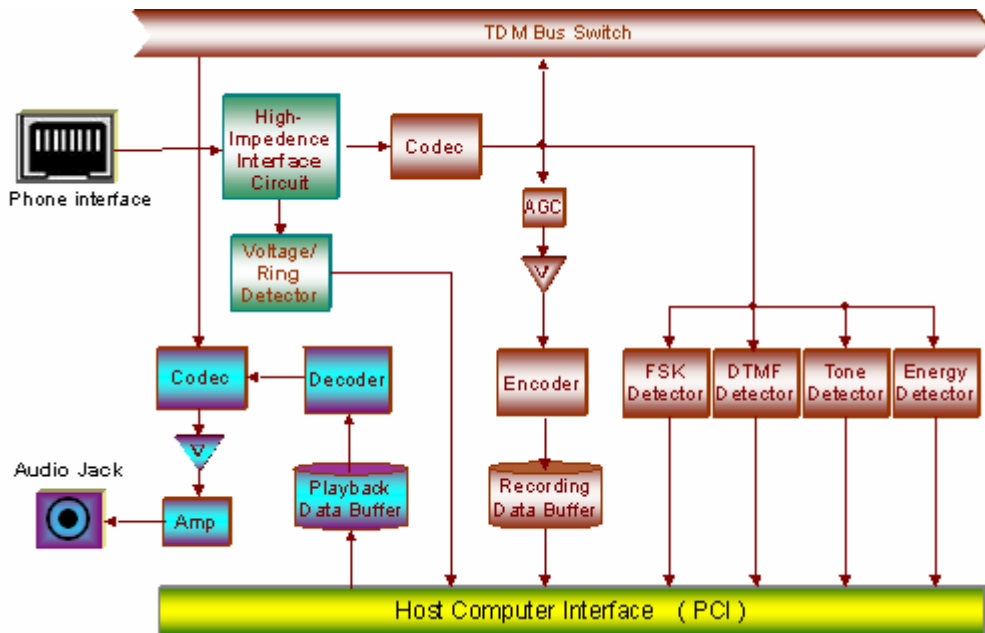

Figure 1-1 Operating Principle

1.4 Functional Modules

This board can be used with two kinds of recording modules: High-impedance recording module and microphone module.

- **High-impedance recording module**

Equipped with high-impedance input interfaces, this module is used for the recording of local lines, extension lines, dynamic microphones and other audio tones. See Figure 2-4 and Figure 2-5 for details.

- **Microphone recording module**

Equipped with battery feed circuits, this module connects directly to condenser microphones (sound-card-compatible common microphones). See Figure 2-6 and Figure 2-7 for details.

Chapter 2 Installation

2.1 Hardware Structure

- SHT-16B-CT/PCI, SHT-16B-CT/PCI/MP3 board

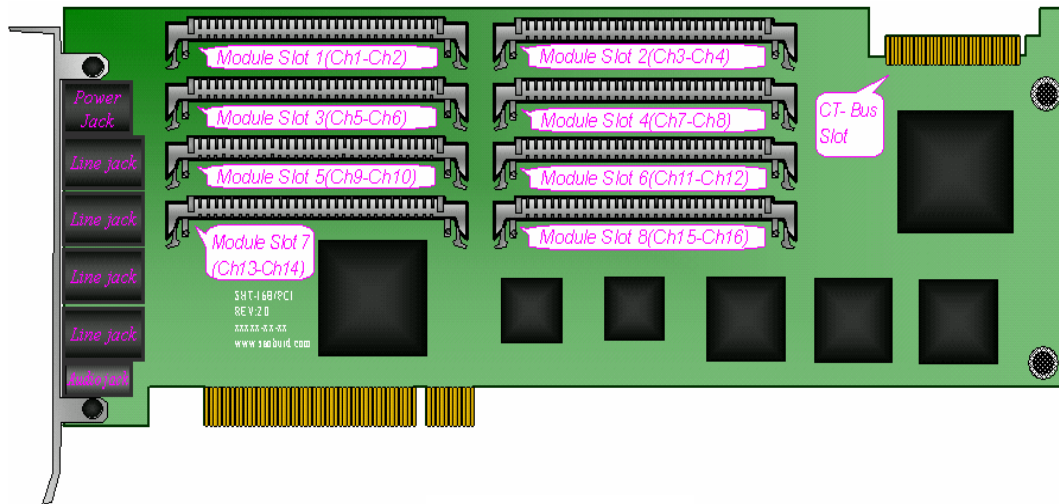

Figure 2-1 Front Side

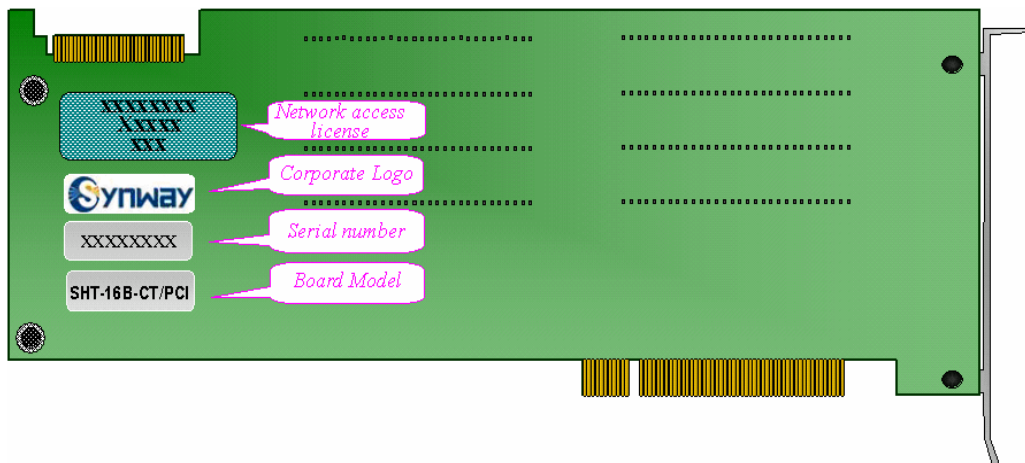

Figure 2-2 Reverse Side

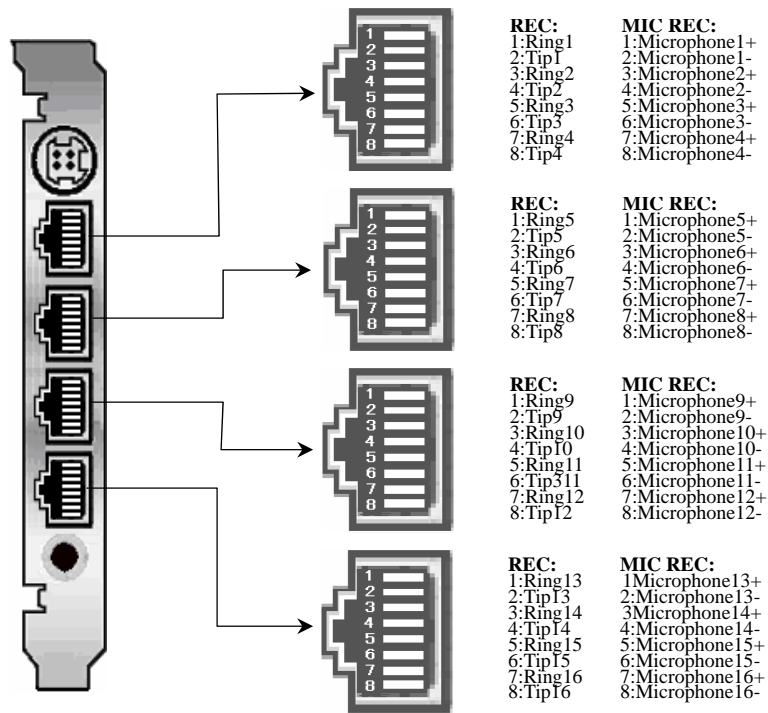

Figure 2-3 Left Side

● On-board high-impedance record module

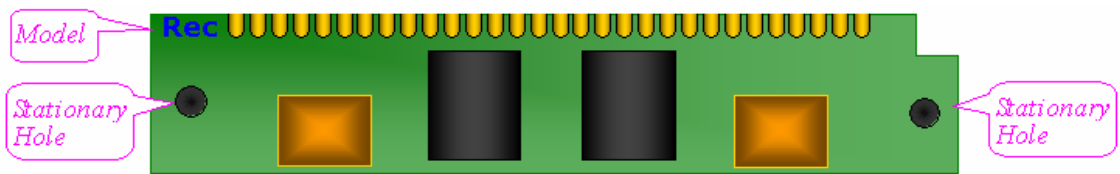

Figure 2-4 Front Side

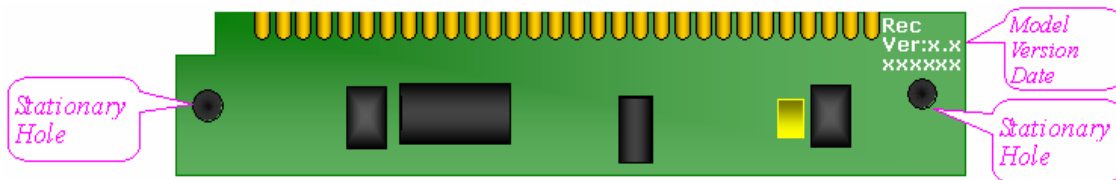

Figure 2-5 Reverse Side

- On-board microphone module

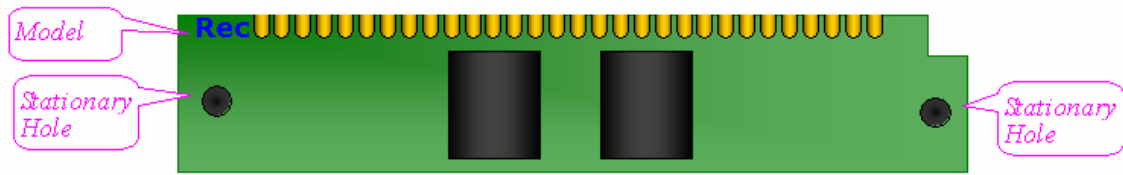

Figure 2-6 Front Side

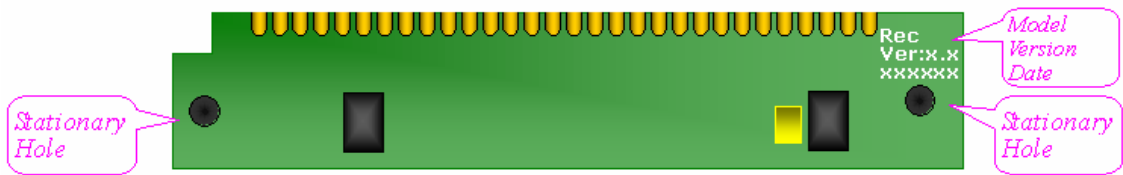

Figure 2-7 Reverse Side

2.2 System Requirements

Host System Requirements

CPU: 300MHz Intel® Pentium® II or above

Memory: 256M or more

HD: Depends on individual requirements

Supported Operating Systems

Refer to *SynCTI Programmer's Manual.pdf*.

2.3 Installation Procedure

Notes: Always turn off the power before installation!

Step 1: Plug the desired module into the on-board module slots, and fit the board into the chassis

Step 2: Connect to analog phone lines or other input signals

Each RJ45 jack has 8 pins, which can be connected to four 2-pin RJ11 jacks via a 4-way hub. See Figure 2-3 for the physical layout of the jack.

Take the first RJ45 jack for example, the matching relationship among the on-board channel numbers, the 8 pins of the RJ45 jack and the 4-way hub is shown in Table 2-1 below.

Interface Serial Number	Channel Number	Pins of the RJ45 Jack	4-way Hub
First RJ45 connector	1	1 st and 2 nd pins	1 st jack
	2	3 rd and 4 th pins	2 nd jack
	3	5 th and 6 th pins	3 rd jack
	4	7 th and 8 th pins	4 th jack

Table 2-1 Matching Relationship among Channel Number, 8 Pins of RJ45 Jack and 4-way Hub

Notes:

- ① Connection to an RJ45 jack can be done through a 4-way hub and the matching relationship for the other three on-board RJ45 jacks and their corresponding pins and channel numbers may be deduced by analogy.
- ② 4-way hubs are available on purchase from our company or if you prefer to construct one by yourself, we suggest you follow Figure 2-3.

Step 3: Connect the microphone module

Skip this step if there is no need to record the condenser microphone.

Notes: We absolutely advise against connecting the microphone module to phone lines from the PBX terminal, or it could be damaged. Pay attention to the pin polarity shown in Figure 2-8 below while connecting lines to the modules.

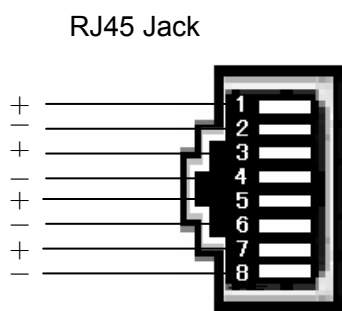

Figure 2-8 Polarity for Connection of Microphone Module

Step 4: Connect the sound box or other proper sound devices

Skip this step if there is no need to 'monitor in real time' or 'play'.

Regarding how to choose proper sound devices, refer to 'Input/output Interface' and 'Audio Specifications' in *Appendix A Technical Specifications*

Notes: The first module slot on the board must be fitted with a module should you wish to play sound via the amplifier.

Step 5: Connect the bus cable with the H.100 bus on each board.

Skip this step if there is no need for bus exchange between multiple boards.

Notes:

- ① See Figure 2-9 for correct insertion. Do not twist or insert in the opposite direction.

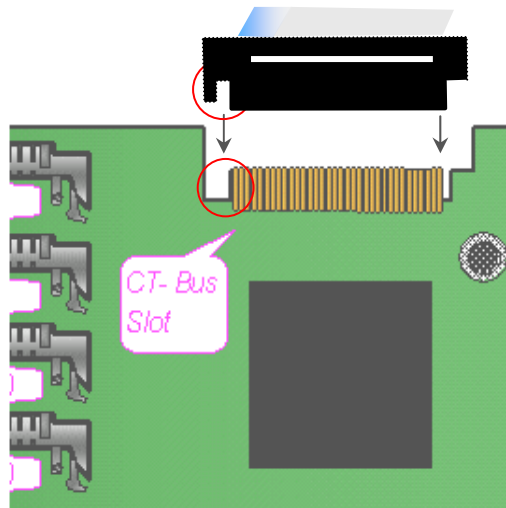

Figure 2-9 Connection of H.100 Bus

- ② There are two clock settings for our boards: When between-board bus exchange is not required, each board sets its own clock and may not connect to the bus cable; otherwise, each board must be connected to the bus cable, following the clock of the cable.
- ③ The bus cable houses stiff conducting material. Therefore, when it has been shaped, do not bend it repeatedly or violently lest it is broken.

Step 6: Boot your computer and install the driver

Regarding driver installation, refer to *Driver Installation Manual*.

Step 7: Set the high-impedance record module to be of high-sensitivity (-20dB) with software

Skip this step if there is no need to input signals into lines or record dynamic microphones.

Key Tips:

- As the system is expected to run for long hours unmanned, 'energy-saving' mode should be turned off for both the CPU and the HD in CMOS or WINDOWS operating system. This is to ensure full-speed operation of the computer, or it may lead to a drop in performance or unexpected errors after running for some time.

- It is important to ground the chassis with analog tap passive boards for safety reasons, according to standard industry requirements. A simple way is earthing with the third pin on the plug. No or improper grounding may cause instability in operation as well as decrease in lightning resistance.

Appendix A Technical Specifications

Dimensions

$310 \times 108 \text{mm}^2$ (excluding L-bracket)

Weight

≈ 400g (including 8 dual channel modules)

Environment

Operating temperature: $0^{\circ}\text{C} - 55^{\circ}\text{C}$

Storage temperature: $-20^{\circ}\text{C} - 85^{\circ}\text{C}$

Humidity: 8% — 90% non-condensing

Storage humidity: 8% — 90%
non-condensing

Input/output Interface

Headset jack: One $\phi 3.5$ stereo jack

Telephone line jack: Four 8-pin RJ45 jacks

Audio Specifications

Codec: CCITT A/ μ -Law 64kbps,

IMA ADPCM 32kbps

Output power: $\geq 50\text{mW}$

Distortion: $\leq 2\%$

Frequency response: 300-3400Hz ($\pm 3\text{dB}$)

Signal-to-noise ratio: $\geq 38\text{dB}$

Echo suppression: $\geq 40\text{dB}$

Maximum System Capacity

Up to 10 boards concurrently per system; up to 16 channels per board

Power Requirements

+5V DC: 600mA

-12V DC: 80mA

+12V DC: 300mA

Maximum power consumption: $\leq 12\text{W}$

(PC power supply only)

Impedance

Input impedance: $\geq 1\text{M}\Omega/500\text{V DC}$;
 $\geq 10\text{k}\Omega/1000\text{V AC}$

Insulation resistance for PC isolation from telephone line: $\geq 2\text{M}\Omega/500\text{V DC}$

Audio Encoding & Decoding

16Bit PCM 128kbps

8Bit PCM 64kbps

A-Law 64kbps

μ -Law 64kbps

VOX 32kbps

ADPCM 32kbps

GSM 13.6kbps

MP3 8kbps

Sampling Rate

8kHz

Safety and Certifications

Lightning Resistance: Level 4

Safety: FCC; CE; CC

Appendix B Technical/sales Support

Thank you for choosing Synway. Please contact us should you have any inquiry regarding our products. We shall do our best to help you.

Headquarters

Synway Information Engineering Co., Ltd

<http://www.synway.net/>

9F, Synway D&R Center, No.3756, Nanhuan Road, Binjiang District, Hangzhou, P.R.China, 310053

Tel: +86-571-88860561

Fax: +86-571-88850923

Technical Support

Tel: +86-571-88864579

Mobile: +86-18905817070

Email: techsupport@sanhuid.com

Email: techsupport@synway.net

MSN: synway.support@hotmail.com

Sales Department

Tel: +86-571-88860561

Tel: +86-571-88864579

Fax: +86-571-88850923

Email: sales@synway.net