



Synway CTI Series

SHT-8C/PCI/FAX

Analog Fax Board

Product Introduction

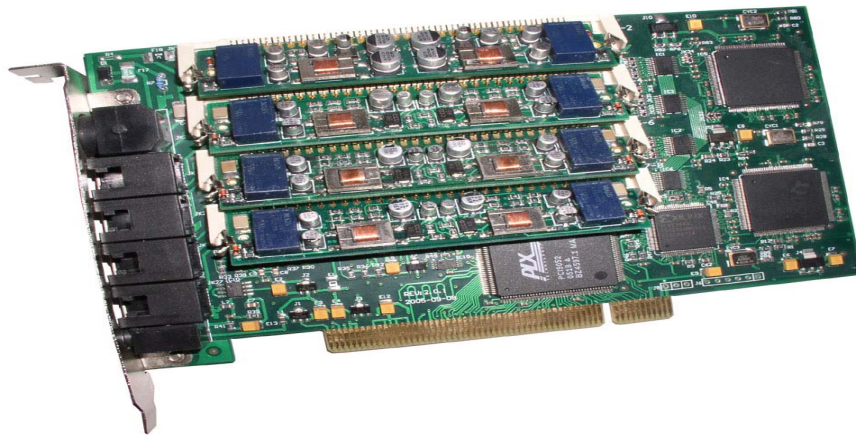

Synway Information Engineering Co., Ltd

www.synway.net

➤ Functions

- A single board can be installed with at most 4 dual-channel modules, supports 8 voice channels
- Supports ring-alert for external calls
- Station phones on-hook/off-hook detection
- Direct connection between trunk and station keeps call uninterrupted during power outage
- Calling party info (Caller ID) detection/transmission, DTMF and FSK support
- Activity/silence detection
- Automatic Gain Control (AGC) support in recording operation
- DTMF transmission and detection
- The fax channel can be shared by all the voice channels, supports the transmit/receive rate of 14400bps
- The flexible distributed conferencing system sets no limit on the number of simultaneous conferences and participants in each conference, allows monitoring and recording of the whole conference and each individual speaker
- Includes audio output interface. The first channel on the board equipped with an analog audio amplifier circuit can directly connect to the headset or sound box, and play voices to a particular channel via a simple function call
- Automatic line voltage detection
- Automatically checks the board to determine the number and type of modules on the board
- Each board has a unique hardware serial number written in the firmware to distinguish itself from other boards and prevent piracy. The number is available via an easy function call with applications
- The on-board authorization code identification circuit is designed for software safety. Users can apply to our company for the authorization code
- The on-board lightning-proof circuit reaches the telecom standard and eliminates the damage caused by the lightning

➤ Characteristic Features

- **PCI 2.1 Bus Support**

Includes PCI 2.1 bus with burst data transmission rate up to 132 MB/s; PNP (plug and play) feature eliminates the need for jumper leads.

- **On-board SIMM Slots**

Fit modules to board. Contacts on both sides greatly improve connection and ease installation.

- **Module Configurable**

4 on-board dual-channel modules can be freely arranged in pairs or groups for various complex, multi-functional applications, such as call center and recording functions available on a single board.

- **Available RJ11 Jack**

The available on-board RJ11 jacks can be directly connected to phone lines or converted via a two-way hub, making connection easy and malfunctions rare.

- **External Ringing Current & Battery Feed Power Supply**

Provides station modules with battery feed, and enables the phones which are linked to station channels to ring.

- **Programmable Tone Detector**

Detects single or dual tones at any frequency, offering facility for use with a variety of PBXes and key telephone systems.

- **Professional Driver Algorithm**

Uses SPECDial - a professional driver algorithm - to perform a complete automatic dial process through analog lines, accurately identifies called-party statuses and precisely distinguishes an answering machine from a fax machine that is responding at the remote end.

- **Echo Cancellation**

The self-adaptive echo cancellation feature effectively eliminates echoes under various conditions, which cancels out the effect of voice playback on DTMF and busy tones detection, avoids self-excited oscillation and howling, and minimizes the possibility of registering wrong DTMF and busy tones in a conference call.

- **Various CODECs Support**

Offers a large selection of voice CODECs, including hardware-based A-Law, μ -Law,

IMA-ADPCM, software-based 16-bit linear PCM, MP3 and VOX.

- **Supports WAV File**

The recorded voice files can be edited and played by audio tools such as Cooledit.

- **Synway's Unified SynCTI Driver Development Platform**

Synway owns the intellectual property rights for the unified high-intelligence SynCTI driver development platform. Each system supports up to 2048 channels. Functions such as the detection and analysis of rings, tones and Caller IDs, are available via simple function calls on the driver platform, without having to understand complex call procedures.

➤ Operation Principle

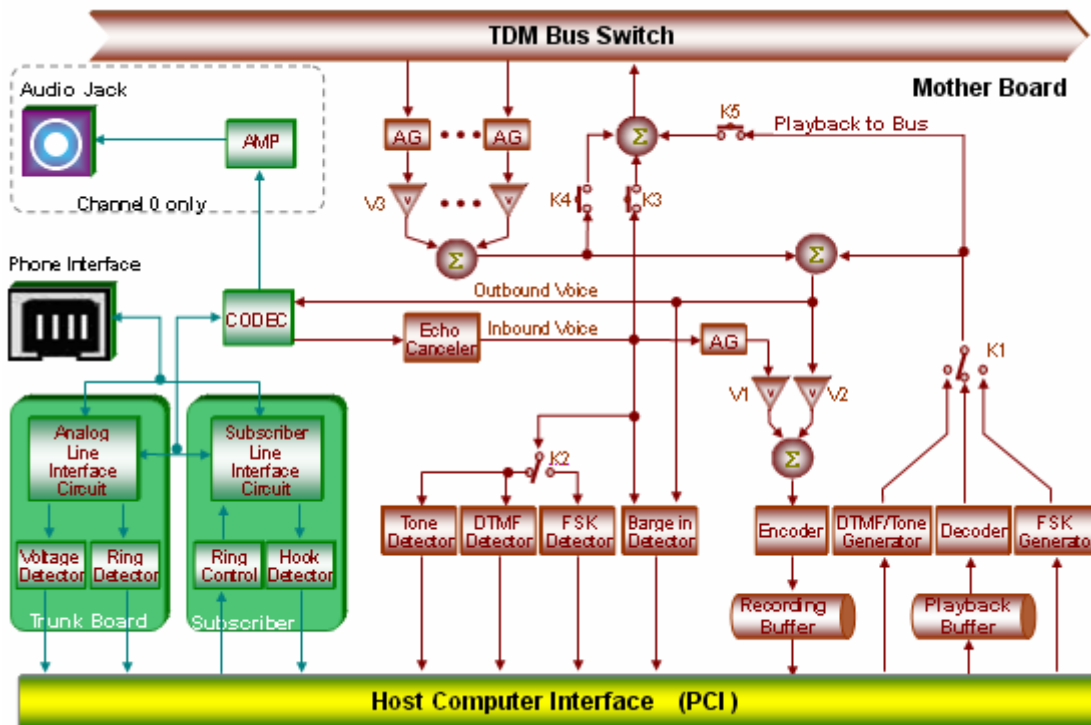

► Typical Application

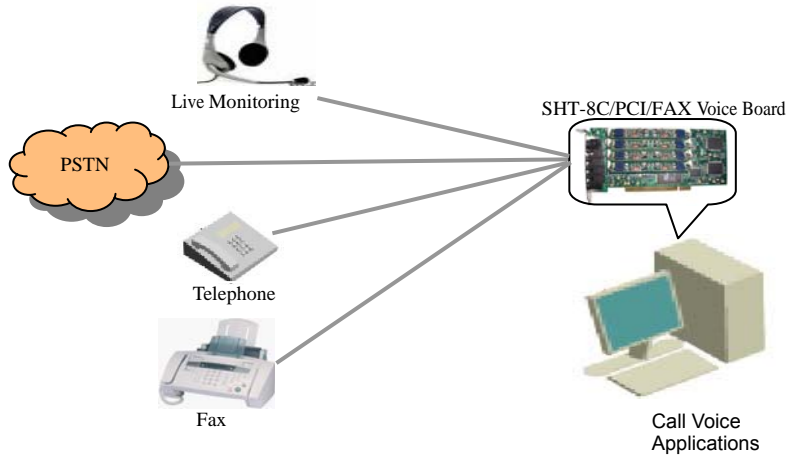

► Technical Specifications

Dimensions

170×115mm² (excluding L-bracket)

Weight

≈ 250g

Environment

Operating temperature: 0 °C—55 °C

Storage temperature: -20 °C—85 °C

Humidity: 8%—90% non-condensing

Storage humidity: 8%—90% non-condensing

Input/output Interface

Headset jack: One ϕ 3.5 stereo jack

Telephone line jack: Four 4-pin RJ11 jacks

Audio Specifications

CODEC: CCITT A/ μ -Law 64kbps,

IMA ADPCM 32kbps

Output power: \geq 50mW

Distortion: \leq 3%

Frequency response: 300-3400Hz (\pm 3dB)

Signal-to-noise ratio: \geq 38dB

Echo suppression: \geq 40dB

Maximum System Capacity

Up to 10 analog fax boards concurrently per system; up to 8 channels per board

Power Requirements

+5V DC: 600mA

-12V DC: 80mA

+12V DC: 300mA

Maximum power consumption: \leq 12W
(PC power only)

Impedance

Input impedance: \geq 1M Ω /500V DC;

\geq 10k Ω /1000V AC

Insulation resistance for PC isolation from telephone line: \geq 2M Ω /500V DC

Telephone line impedance:

Compliant with the national standard impedance for three-component network

Audio Encoding & Decoding

16Bit PCM 128kbps

8Bit PCM 64kbps

A-Law 64kbps

μ -Law 64kbps

VOX 32kbps

ADPCM 32kbps

GSM 13.6kbps

MP3 8kbps

Sampling Rate

8kHz

Safety

Lightning resistance: Level 4

➤ Purchasing Guide

The Synway CTI Series SHT-8C/PCI/FAX board provides a complete range of features to meet all requirements.

Model	PC Bus	Voice Channels	Conferencing	Echo Cancellation	Faxing	Board TDM	Between-board TDM
SHT-8C/PCI/FAX	PCI	8	√	√	√	√	—

➤ Technical/sales Support

Headquarters

Synway Information Engineering Co., Ltd

<http://www.synway.net/>

9F, Synway D&R Center, No.3756, Nanhuan Road, Binjiang District, Hangzhou, P.R.China, 310053

Tel: +86-571-88860561

Fax: +86-571-88850923

Technical Support

Tel: +86-571-88864579

Mobile: +86-13735549651

Email: techsupport@sanhuid.com

Email: techsupport@synway.net

MSN: scycindy_sh@hotmail.com

Sales Department

Tel: +86-571-88860561

Tel: +86-571-88864579

Fax: +86-571-88850923

Email: sales@synway.net

TIPS

- All the content and data herein have been scrupulously checked. However, we do not guarantee the absence of errors.**
 - Product specifications and relevant data are subject to conditions on the purchase contract.**
 - Our company reserves the right to modify this document without prior notice and the right for final explanation.**
-